

Demonstration

- Speech-to-Speech Translation Technologies @ NICT-ATR -

Tohru Shimizu, Yutaka Ashikari, Eiichiro Sumita,
Hideki Kashioka, and Satoshi Nakamura

Multi-lingual speech-to-speech translation system

■ Overview

- Corpus-based approach enables wide coverage, robustness and portability to new languages and domains.

■ Signal processing

- Realizes robustness for real use of speech translation in noisy environments.
 - Noise suppression based on particle filtering
 - MMSE estimator using a GMM

Multi-lingual speech-to-speech translation system

■ **Speech recognition**

- Compact and accurate model from limited size corpora.
 - Acoustic modeling:
 - MDL-SSS
 - Adapted to several accents
e.g., US (the United States), AUS (Australia),
and BRT (Great Britain) for English.
 - Language modeling:
 - Composite multi-class N-gram

Multi-lingual speech-to-speech translation system

■ Machine translation

- Automatically constructed from large-scale corpora in the travel domain.
 - Phrase-based SMT system, and EM

■ System Integration

- Easy assembly of speech communication system from the corresponding software modules.
- Designed for use at mobile terminals.
 - Multi-lingual speech communication platform

Configuration of speech-to-speech translation system

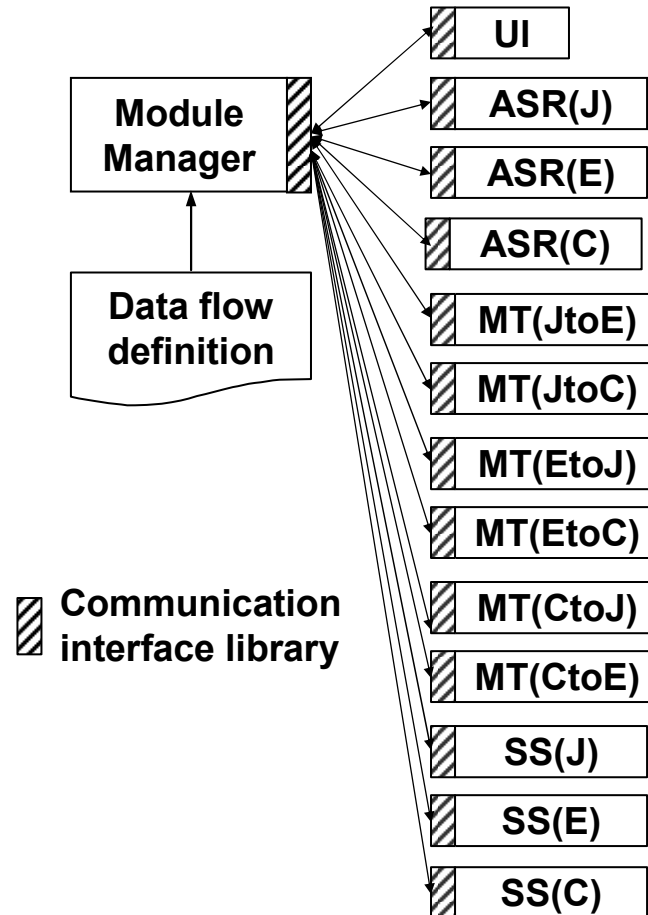

Configuration of speech-to-speech translation system (Stand alone)

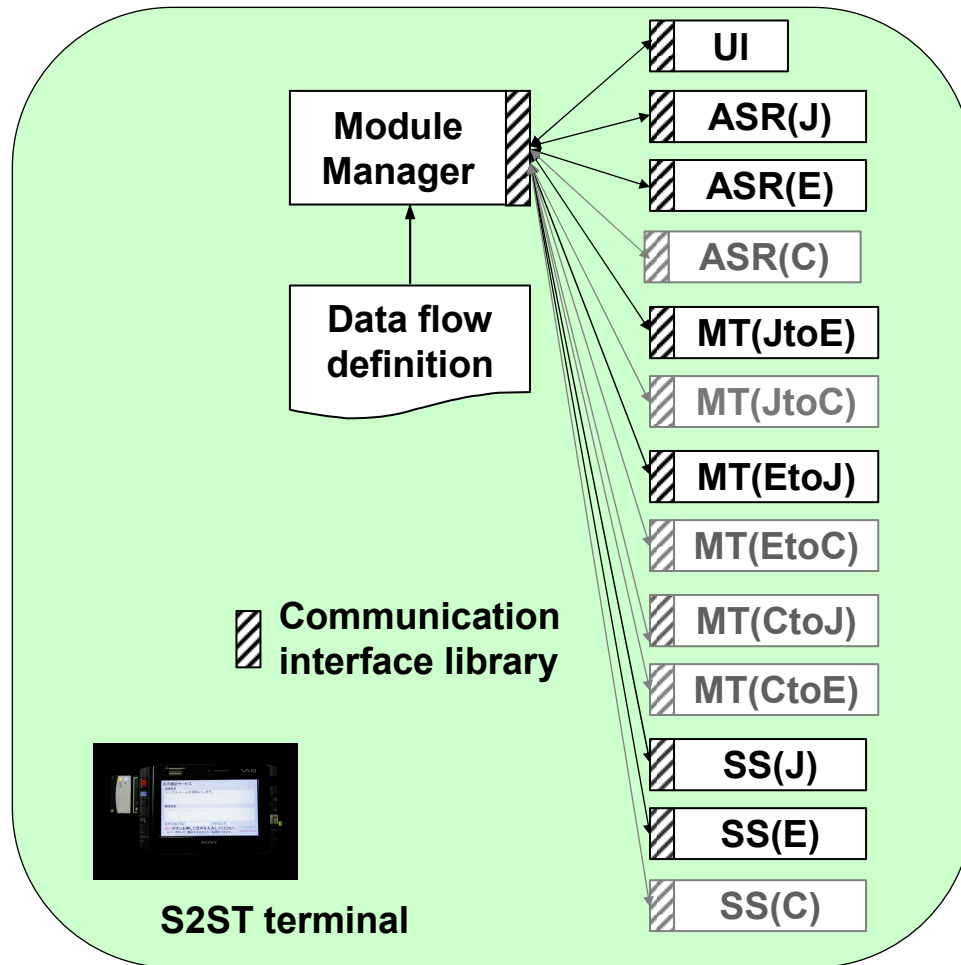

Configuration of speech-to-speech translation system (Client-server)

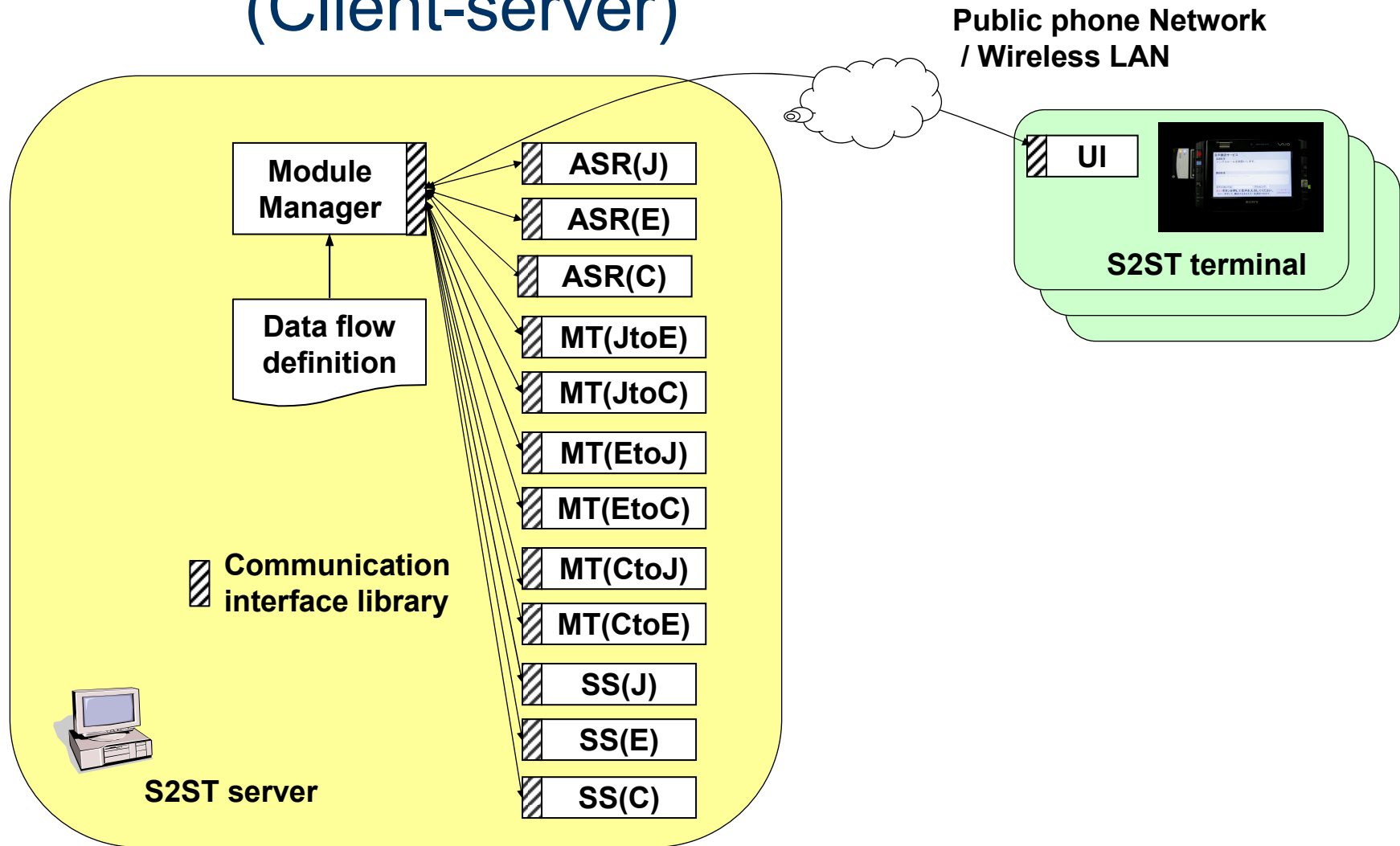

Demonstration

- S2ST terminal

JtoE

音声翻訳サービス

認識結果:

ASR results

翻訳結果:

MT results

音声メータ: クリッピング:

赤いボタンを押して入力して下さい。

J=>E

PCM

再選択

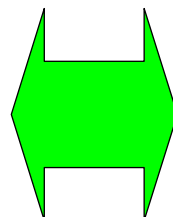

EtoJ

Speech Translation Service

Recognition Result:

ASR results

Translation Result:

MT results

Voice Level: Clipping:

Push **RED** Button, and speak.

E=>J

PCM

Reselect

