

Development of a New VLBI Sampler Unit (K5/VSSP32) Equipped with a USB 2.0 Interface

Tetsuro Kondo, Yasuhiro Koyama, Hiroshi Takeuchi, Moritaka Kimura

Kashima Space Research Center, National Institute of Information and Communications Technology

Contact author: Tetsuro Kondo, e-mail: kondo@nict.go.jp

Abstract

National Institute of Information and Communications Technology (NICT) has developed a new VLBI sampler unit named K5/VSSP32 dedicated to e-VLBI which is a successor to the K5/VSSP. The maximum sampling frequency per channel of the K5/VSSP32 is 64 MHz, which is four times as fast as that of K5/VSSP. In addition to the maximum sampling frequency, there is a difference in the interface to a host PC. A USB 2.0 (Universal Serial Bus specification revision 2.0) interface is used to connect the sampler with a host PC in the K5/VSSP32, while a PCI-bus interface is in the K5/VSSP. It is hence possible to use even a notebook PC for VLBI observations with the K5/VSSP32.

1. Introduction

National Institute of Information and Communications Technology (NICT) has developed a new sampler dedicated to geodetic VLBI system named K5/VSSP32 that is equipped with a USB 2.0 (Universal Serial Bus specification revision 2.0) interface. Recent samplers developed by NICT are categorized into two types: One is K5/VSI series equipped with a VSI (VLBI Standard Interface) interface and the other is K5/VSSP series aiming at direct connection with a PC. K5/VSSP32 belongs to the latter category. K5/VSSP is the name of the sampler developed first in this category in order to reduce network-cost and to improve interconnectivity with other sites in real-time VLBI system. K5/VSSP sampler is a PCI bus board mountable on a motherboard of standard PC and has a maximum sampling frequency of 16 MHz per channel. It has contributed to broaden the base for VLBI users, i.e., any PC equipped with a K5/VSSP PCI-bus board can be a VLBI recorder, and the data transfer through the Internet is easily realized. K5/VSSP has also progressed greatly the development of software correlator. K5/VSSP32 is a successor to the K5/VSSP, but a USB 2.0 is newly adopted as an interface with a host PC. Maximum sampling frequency per channel is increased up to 64 MHz. As a K5/VSSP32 unit has 4 channel analog inputs, 4 units can cover 16 channels which is sufficient number of channels in case of geodetic VLBI. In the meantime, K5/VSSP32 can connect to a notebook PC or a laptop PC through USB 2.0 interface. It is hence possible to use a notebook PC as a recorder not only for a VLBI observation but also for a general purpose observation such as acquiring geophysical data. We carried out a VLBI fringe test using both a desktop PC and a notebook PC, and we successfully got fringes.

2. K5/VSSP32 sampler

Figure 1 shows a block diagram of K5/VSSP32 sampler unit. There are 4 analog input channels in a unit. Each channel signal is fed to an operational amplifier (AD8061) that has the bandwidth

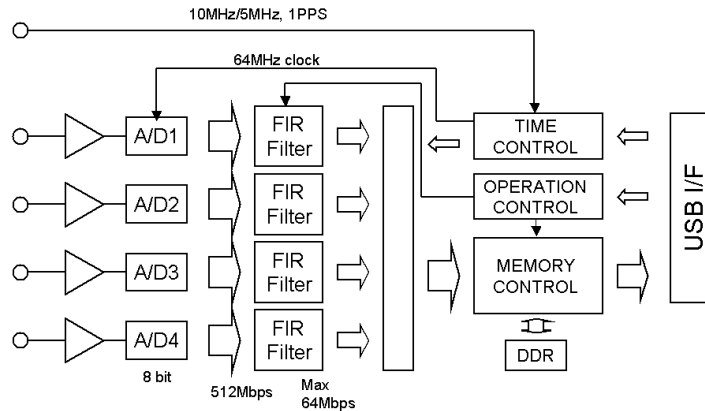

Figure 1. A block diagram of K5/VSSP32 sampler.

of 300 MHz, then it is sampled by using an 8-bit analog-to-digital (A/D) converter (AD9283) with the sampling frequency of 64 MHz. The AD9283 has the input bandwidth of 475 MHz that is wider than that of the AD8061, thus signals up to 300 MHz, which is limited by the input operational amplifier AD8061, can be handled by the K5/VSSP32 sampler. Each digitized signal is fed to a digital filter section equipped by using an FPGA. Low-pass-filters (LPFs) of cut-off frequency of 2, 4, 8, 16, and 32 MHz are implemented in the digital filter section. Insertion of LPFs or bypassing filter is selectable from a host PC. Each filtered signal is re-sampled with sampling parameters given from a host PC and is formatted into 1 second frame data that has a format compatible with the K5/VSSP but has an expanded header. Clock signals to operate the K5/VSSP32 sampler are generated from a reference signal. Either 10 MHz or 5 MHz signal can be used as a reference signal. The FPGA (Altera EP2S30) that is the same one where digital filters are implemented carries out these signal processing. A USB 2.0 is equipped as an interface with a host PC. Figure 2 shows a picture of K5/VSSP32 unit and 16-ch module consisting of 4 units. Table 1 summarizes the specifications of K5/VSSP32 compared with the K5/VSSP.

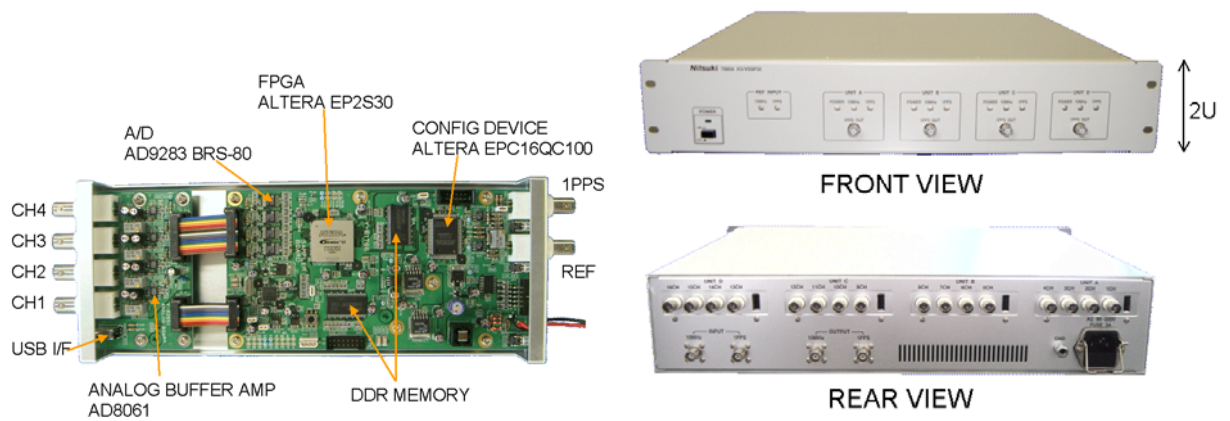

Figure 2. A picture of K5/VSSP32 unit (left) and 16-ch K5/VSSP32 module (right).

Table 1. Specifications of K5/VSSP and K5/VSSP32

	K5/VSSP	K5/VSSP32
Sampling frequency (MHz)	0.04, 0.1, 0.2, 0.5, 1, 2, 4, 8, 16	0.04, 0.1, 0.2, 0.5, 1, 2, 4, 8, 16, 32, 64
LPF (digital filter)(MHz)	–	2, 4, 8, 16, through
Analog bandwidth	100 MHz	300 MHz
AD bits	1, 2, 4, 8	1, 2, 4, 8
# of ch/unit	4	4
Maximum data rate	64 Mbps/ch 64 Mbps/unit 256 Mbps/4units	64 Mbps/ch 256 Mbps/unit 1024 Mbps/4units
DC offset	not adjustable	adjustable from a host PC
Reference signals	1 PPS, 10 MHz	1 PPS, 10 MHz / 5 MHz
Header size	64 bits	256 bits (typical) *
Interface with PC	PCI-bus	USB2.0

* 96 bits (fixed) + variable auxiliary field (160 bits typical)

2.1. Fringe test

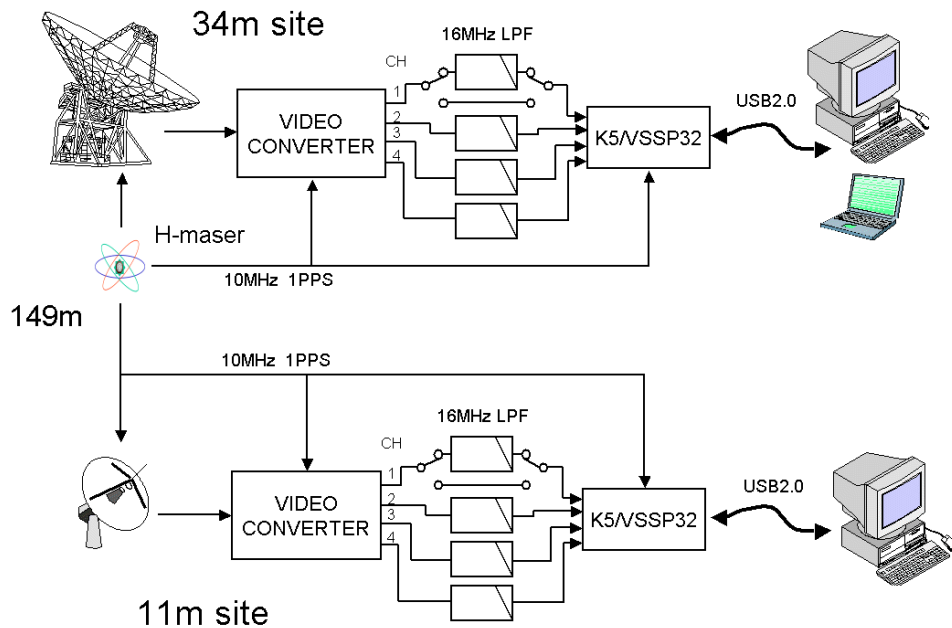

Figure 3. A block diagram of test observation.

A test observation using the K5/VSSP32 sampler was carried out on Nov.10, 2005 using a 34-m antenna and an 11-m antenna at Kashima (baseline length is about 149 m). Figure 3 shows

a block diagram of the test observation. A prototype model of K5/VSSP32 was used at the test observation, and any digital filter was not implemented at that time. Therefore we used an analog low-pass-filter to reduce aliasing. A desktop PC was used as a host PC at both the 34-m and 11-m antenna sites. A notebook PC (Dell INSPIRON 700m) was also used as a host PC at the 34-m antenna site. Table 2 summarizes scan information and sampling parameters at the test observation.

Table 2. Summary of test observation on Nov.10, 2005

RF frequency	CH1: 8210.99 MHz CH2: 8220.99 MHz CH3: 8250.99 MHz CH4: 8310.99 MHz
PCAL signals	34-m antenna : 1 MHz step 11-m antenna : 5 MHz step
Sampling parametrs	32 MHz \times 1 bit \times 4 ch 32 MHz \times 1 bit \times 1 ch 64 MHz \times 1 bit \times 1 ch
Sources	3C345, 3C84
Scan information	Scan #1 07:11:00–07:11:10 3C345 32MHz \times 1bit \times 4ch Scan #2 07:13:30–07:13:40 3C345 64MHz \times 1bit \times 1ch Scan #3 07:18:00–07:18:10 3C84 64MHz \times 1bit \times 1ch Scan #4 07:19:30–07:19:40 3C84 32MHz \times 1bit \times 4ch Scan #5 07:24:00–07:24:10 3C84 32MHz \times 1bit \times 1ch *

* A notebook PC was used at 34-m antenna

Observed data was processed by using the K5 software correlator[1] immediately after observation finished. Correlation results are shown in Figure 4 for CH 1. Periodic component with a period of 0.2 μ sec seen in the delay direction (seen clearly in Scan #1) is due to the phase calibration (PCAL) signals injected to both antennas. Correlations between PCAL signals appear as periodic signals with the period being inverse of the least common multiple of each PCAL signal's frequency step, i.e., 0.2 μ sec(=1/5MHz). Baseline length is short (\sim 149 m) and expected fringe rate is only 0.1 Hz or less. Moreover integration period is only 5 \sim 6 seconds, so that correlations between PCAL signals is not well-separated from those derived from the radio source on the fringe rate domain. Although correlations of PCAL signals are overlapped with fringes from the radio source, we can see a clear peak at the center on the delay and fringe-rate space for all scans. As the center position corresponds to a-priori delay and fringe rate calculated from the antenna position and radio-source position, we can conclude that we could get a good fringe for all scans. In particular, fringe obtained for scan #5 is the memorable first one observed by a notebook PC.

3. Conclusion

We have developed a new sampler named K5/VSSP32, which is a successor to the K5/VSSP and is equipped with a USB 2.0 interface. Maximum sampling frequency is increased up to 64 MHz and maximum data rate per unit is also increased up to 256 Mbps. Adoption of USB2.0 interface

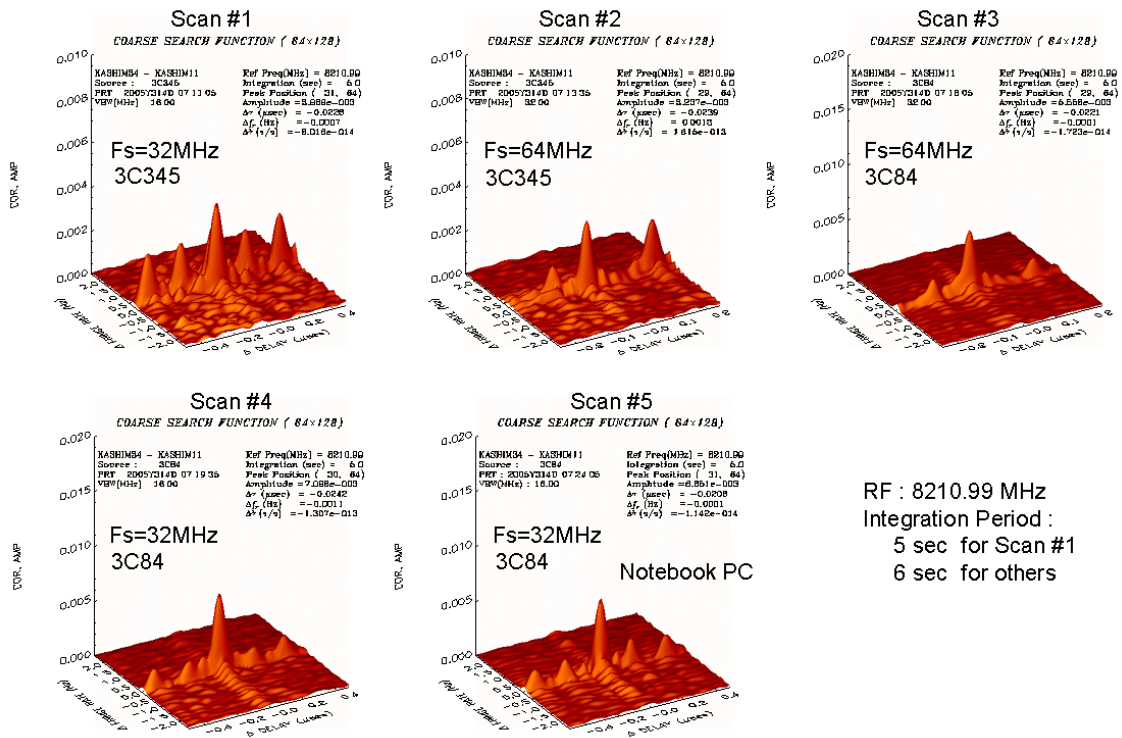

Figure 4. Correlation results for CH 1.

enables us to use a notebook or laptop PC as a host PC of the sampler. Thus K5/VSSP32 can be used for a not only a VLBI observation but also a general-purpose geophysical observation which requires precise time label. A fringe test using K5/VSSP32 demonstrated that the new sampler has a good performance in terms of system coherence. We also got the first fringe successfully as an observation using a notebook PC. We will carry out a 24-hour experiment using the K5/VSSP32 to verify the performance as a geodetic VLBI sampler.

References

- [1] Kondo, T., M. Kimura, Y. Koyama, and H. Osaki, Current status of software correlators developed at Kashima Space Research Center, *IVS 2004 General Meeting Proceedings*, edited by N. R. Vandenberg and K. D. Baver, NASA/CP-2004-212255, 186–190, 2004.