

Kashima 34-m Radio Telescope

Hiroshi Takiguchi, Eiji Kawai, Hiromitsu Kuboki, Tetsuro Kondo

Abstract

The Kashima 34-m radio telescope is continuously operated and maintained by the National Institute of Information and Communications Technology (NICT) as a facility of the Kashima Space Reserch Center (KSRC) in Japan. This brief report summarizes the status of this telescope, the staff and activities during 2007.

1. General Information

The Kashima 34-m radio telescope (Figure 1 left) was constructed by NICT (at that time the Communications Research Laboratory) as a main station of the "Western Pacific VLBI Network Project" in 1988. After that project has ended, this telescope has been used by not only for geodetic purposes but also for astronomy and other purposes [1] [4]. The station is located about 100 km East of Tokyo, Japan and co-located with the 11-m radio telescope and the International GNSS Service station (KSMV) (Figure 1 right). During 19 years of operation, this telescope has been kept in a fairly good condition. This station is maintained by the Space-Time Applications Project of the Space-Time Standards Group of KSRC, NICT.

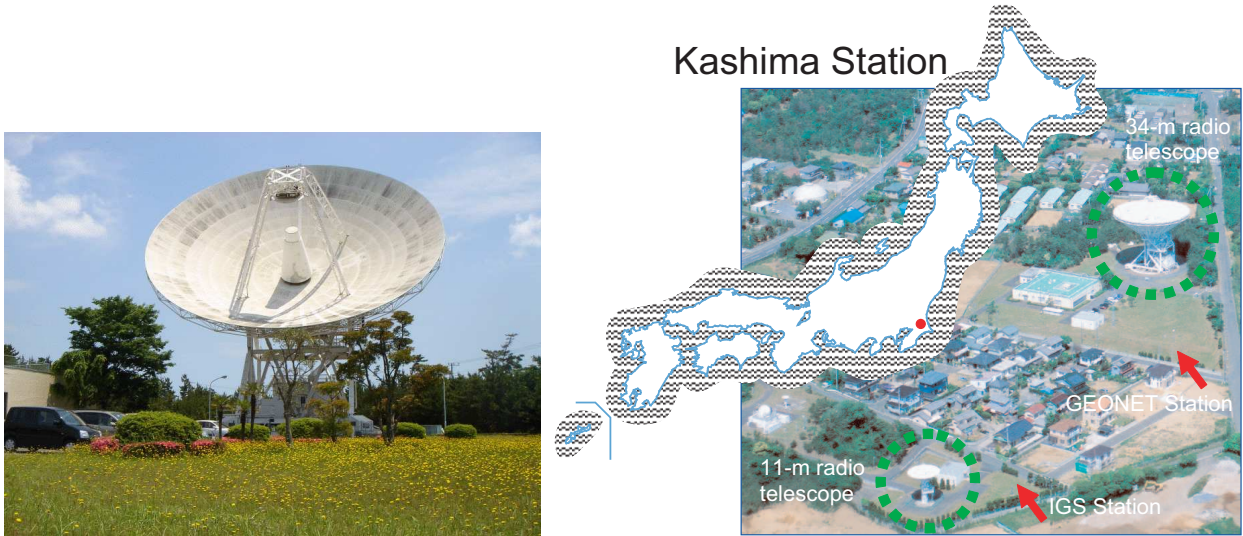

The Kashima 34-m radio telescope.

The layout map of Kashima station.

Figure 1. The Kashima Station.

2. Component Description

The Kashima 34-m radio telescope can observe L, C, K, Ka, Q, S, and X-bands. The main specification of the telescope and receivers are summarized in Table 1 and Table 2.

Table 1. Main specifications of the 34-m radio telescope.

Main reflector aperture	34.073 m
Latitude	N 35° 57' 21.78"
Longitude	E 140° 39' 36.32"
Height of AZ/EL intersection above sea level	43.4 m
Height of azimuth rail above sea level	26.6 m
Antenna design	Modified Cassegrain
Mount type	AZ-EL mount
Drive range azimuth	North $\pm 270^\circ$
Drive range elevation	7°-90°
Maximum speed azimuth	0.8°/sec
Maximum speed elevation	0.64°/sec
Maximum operation wind speed	13 m/s
Panel surface accuracy r.m.s.	0.17 mm

Table 2. The receiver specification of the 34-m radio telescope.

Band	frequency (MHz)	Trx (K)	Tsys (K)	Efficiency	SEFD (Jy)	Polarization
L	1350-1750	18	45	0.68	200	L/R
S	2193-2350	19	72	0.65	340	L/R
C	4600-5100	100	127	0.70	550	L(R)
X-n	8180-9080*	41	52	0.68	230	L/R
X-wL	8180-9080#	41	53	0.68	290	L/R
X-wH	7860-8360#	-	50	0.68	270	L/R
K	22000-24000*	105	141	0.5	850	L(R)
Ka	31700-33700	85	150	0.4	1100	R(L)
Q	42300-44900	180	350	0.3	3500	L(R)

* : 8GHz LNA narrow band use. # : 8GHz LNA wide band use.

★ : changed due to the repair in 19 January, 2007.

The original frequency coverage of the X-band was from 7860 MHz to 8600 MHz. In order to respond to IVS observation, we expanded the frequency range of the X-band receiver up to 9080 MHz [2]. About S-band, we installed the new high-temperature superconductor (HTS) band-pass filter to mitigate the radio frequency interference (RFI) signal due to a third-generation mobile phone system (IMT-2000) [3].

3. Staff

The engineering and technical staffs of the Kashima 34-m radio telescope are listed in Table 3. Hiromitsu Kuboki left NICT and Kazuhiro Takefuji joined in December 2007.

Table 3. The engineering and technical staffs of the Kashima 34-m radio telescope.

Name	Main Responsibilities
Eiji Kawai	responsible for operations and maintenance
Mamoru Sekido	software and reference signals
Hiromitsu Kuboki	mechanical and RF related parts
Kazuhiro Takefuji	mechanical and RF related parts
Yasuhiro Koyama	international e-VLBI
Tetsuro Kondo	software correlator developments and e-VLBI

4. Current Status and Activities

The 34-m radio telescope contributed to various experiments (geodesy, radio-astronomy, space navigation, time transfer etc.). Statistical charts of the telescope operation time according to the purpose including maintenance is shown in Figure 2. The total operation time of 2007 was 2319 hours which increased greatly compared with the previous year. The reason for this is because big troubles didn't occur at the telescope [4].

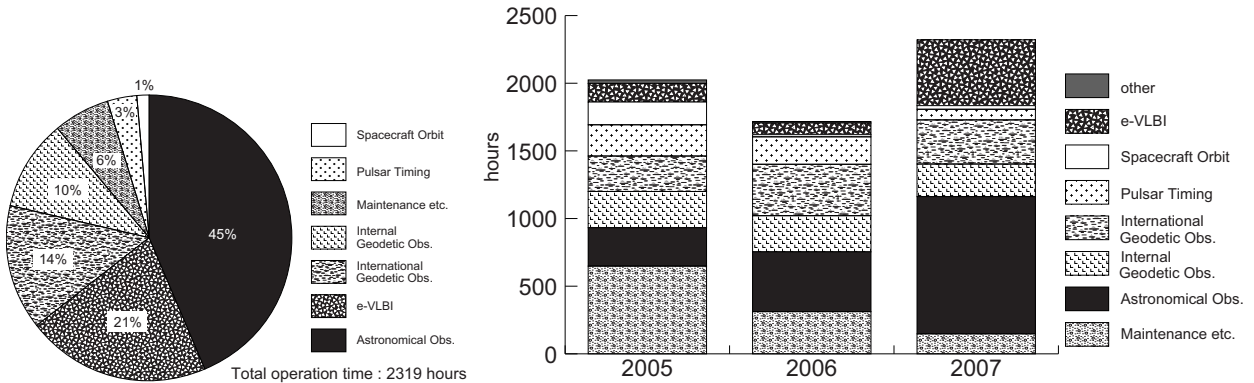

Statistical charts of the telescope operation time according to the purpose. Telescope operation time within the last three years.

Figure 2. Statistical charts of the telescope operation time.

The yearly maintenance was carried out from the beginning of August until end of September. The repair places were the backing structure of the telescope, and the access ladder of the main reflector and the sub-reflector [4].

Figure 3 shows the block diagram of the current S/X-band receiver system [4].

5. Future Plans

The Kashima 34-m radio telescope is a main telescope of our project and already a lot of observations such as "experiment for the development of a 1.6m antenna system", "ultra-rapid UT1 experiment with e-VLBI", and "VLBI experiment for Time Transfer" have been scheduled. Also we are planning the yearly maintenance to keep up the telescope's good condition. Additionally,

Kashima 34m Antenna 2007_12 - S/X Frontend (current)

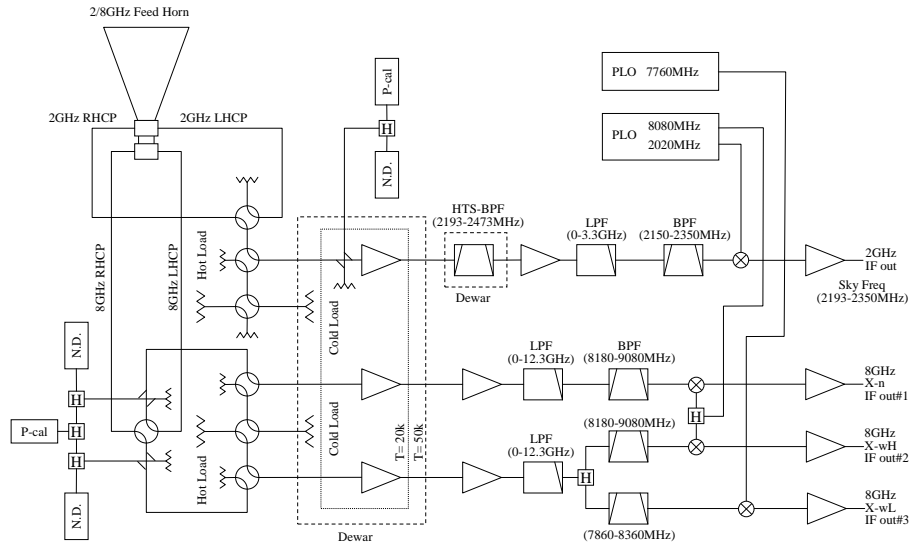

Figure 3. The block diagram of the Kashima 34-m radio telescope S/X receiver after December 2007.

we are planning to restore the following items to improve the telescope's condition.

- Brake malfunction (occurs rarely)
- Creak at the AZ wheel rotation part
- Rust of the backing structure
- Deterioration of the AZ base plate and rail
- Stain of the main reflector

References

- [1] Kawai, E., H. Kuboki, Kashima 34-m Radio Telescope, In: International VLBI Service for Geodesy and Astrometry 2006 Annual Report, NASA/TP-2007-214151, D. Behrend and K. D. Baver (eds.), 51-54, 2007.
- [2] Kawai, E., H. Kuboki, Y. Koyama, T. Kondo, On the expansion of the frequency coverage of an X-band of Kashima 34-m antenna, IVS NICT TDC News, 26, 23-25, 2005.
- [3] Kawai, E., J. Nakajima, H. Takeuchi, H. Kuboki, T. Kondo, M. Suzuki, K. Saito, RFI mitigation at a 2GHz band by using a wide-band high-temperature superconductor filter, J. Geod. Soc. Japan, 2007 (in press).
- [4] Space-Time Standards Group, NGNC, NICT, Kashima 34-m Radio Telescope 2007 Annual Report, 2008 (in Japanese).