



K5システム

NICT鹿島宇宙通信研究センター
小山泰弘

R&D after the K4 (KSP) VLBI System

- Giga-bit VLBI System
 - GBR1000, TDS784 (Giga-bit Sampler), ADS1000, GICO, GICO2, ...
- IP-VLBI Board
- PC-VSI Board



Concept of the K5 System

	K3	K4	K5
Data Recorders	Magnetic Tapes Longitudinal Recorders	Magnetic Tapes Rotary Head Recorders	Hard Disks
e-VLBI	Telephone Line	ATM	IP
Correlators	Hardware	Hardware	Software
	1983~	1990~	2002~
	M96 Recorder, K3 Formatter, K3 VC, K3 Correlator	DIR-1000, -L -M, DFC1100, DFC2100, K4 VC (Type-1, 2), TDS784, ADS1000, GBR1000, GBR2000D, K4 Correlator, KSP Correlators, GICO, GICO2	IP-VLBI (K5/VSSP), PC-VSI (K5/VSI), ADS1000, ADS2000,

K5 Family : Concept

ADS1000

(1024Msample/sec 1ch 1bit or 2bits)



ADS2000

(64Msample/ch·sec, 16ch, 1bit or 2bits)

VSI



PC-VSI Board
(Supports VSI-H specifications)

VSI

Internet

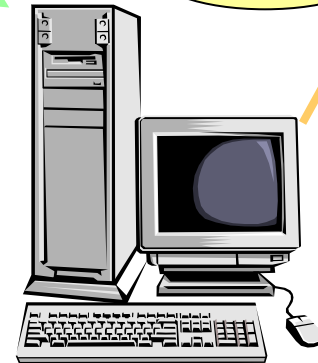

PC : Data Acquisition
Correlation



IP-VLBI Board
(~16Msample/ch·sec, ~4ch, ~8bits)

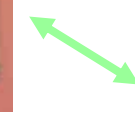
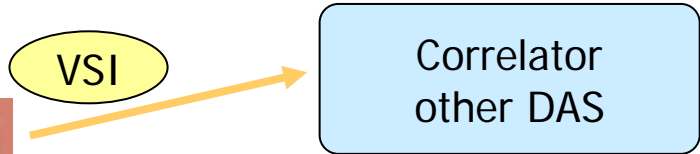
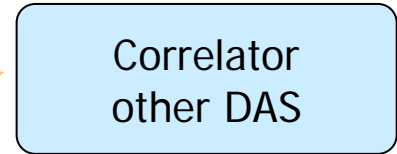

K5 Family : Selection of Samplers

	K5/VSSP	ADS1000	ADS2000
Sampling Speed	40, 100, 200, 500kHz, 1, 2, 4, 8, 16MHz,	1024MHz	64MHz
Sampling Bits	1, 2, 4, 8	1, 2	1, 2
No. Channels	1, 4, 16 (with 4PCs)	1	16
Max. Data Rate	512Mbps (with 4PCs)	2048Mbps	2048Mbps



K5/VSSP



ADS1000



ADS2000

K5/VSSP System

- VSSP = Versatile Scientific Sampling Processor
- 4 Pentium PCs
 - CPU : Pentium-4
 - 1.2GHz (1st Unit)
 - 2.4GHz (2nd Unit)
 - OS : FreeBSD (Linux is also possible)
 - One K5.VSSP board (PCI) in each PC
 - 120Gbyte HDx4x4 ~ 2.8days@64Mbps
- 16ch base-band signal amplifier
- Standard Signal Distributor
 - 10MHz and 1PPS signals for 4 units



K5/VSSP System Data Flow

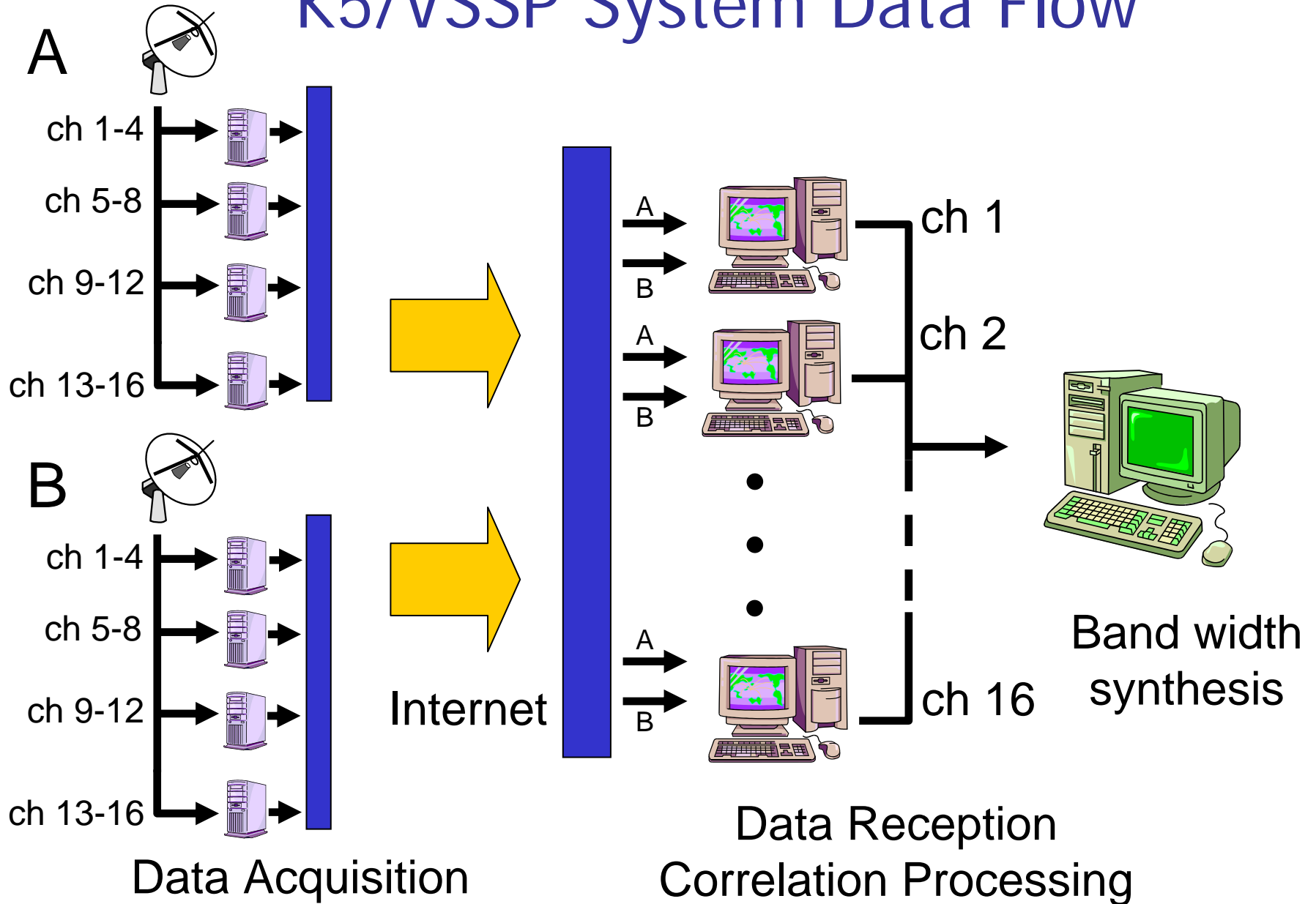

Distributed Software Correlation (1)



K 5 相関処理ステータス

通信総合研究所鹿島宇宙通信研究センター
Communication Research Laboratory

実験コード名	データ総数	処理済	処理中	処理待ち
JD0306	28	3	3	22

Obs	Baseline	Apri file	Mark	host	Start	Stop
1	KASHIMA-GIFU11	ape197020000RYc.bt	●	byakko	031118180719	031118183127
2	KASHIMA-GIFU11	ape197020610RYc.bt	●	seinyuu	031118180733	031118211308
3	KASHIMA-GIFU11	ape197021950RYc.bt	●	byakko	031118183128	031118113510
4	KASHIMA-GIFU11	ape197022640RYc.bt	●	seinyuu	031118211309	*****
5	KASHIMA-GIFU11	ape19702305RYc.bt	●	byakko	031118213511	*****
6	KASHIMA-GIFU11	ape19702305RYc.bt	●	K5la	031118213623	*****
7	KASHIMA-GIFU11	ape19702305RYc.bt	●	*****	*****	*****
8	KASHIMA-GIFU11	ape19702305RYc.bt	●	*****	*****	*****

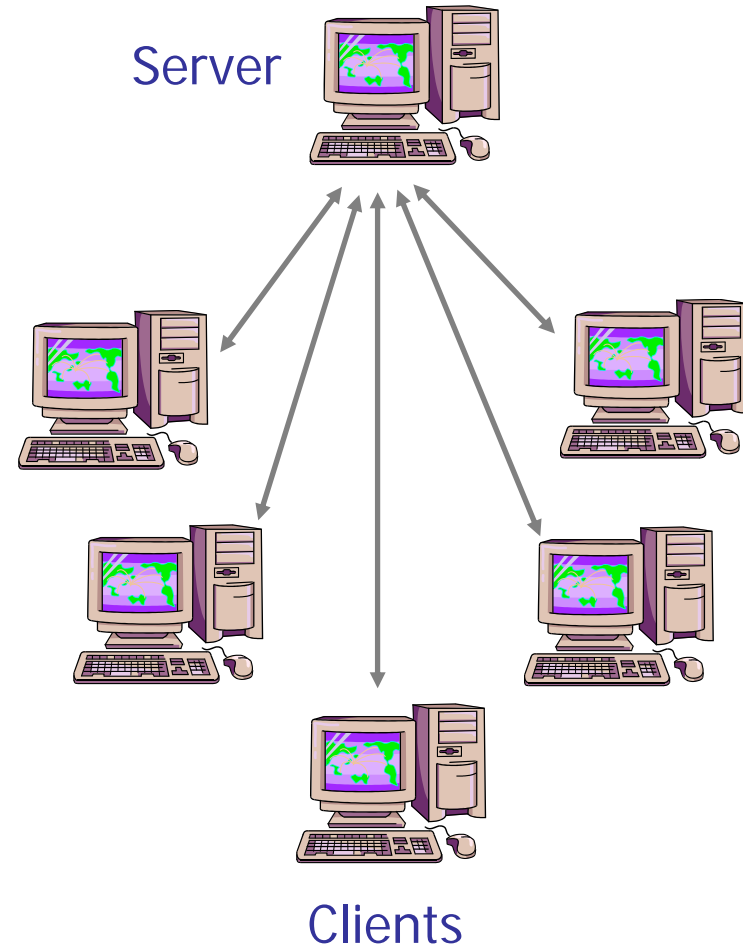

Correlation Master Table / Database

Distributed Software Correlation (2)

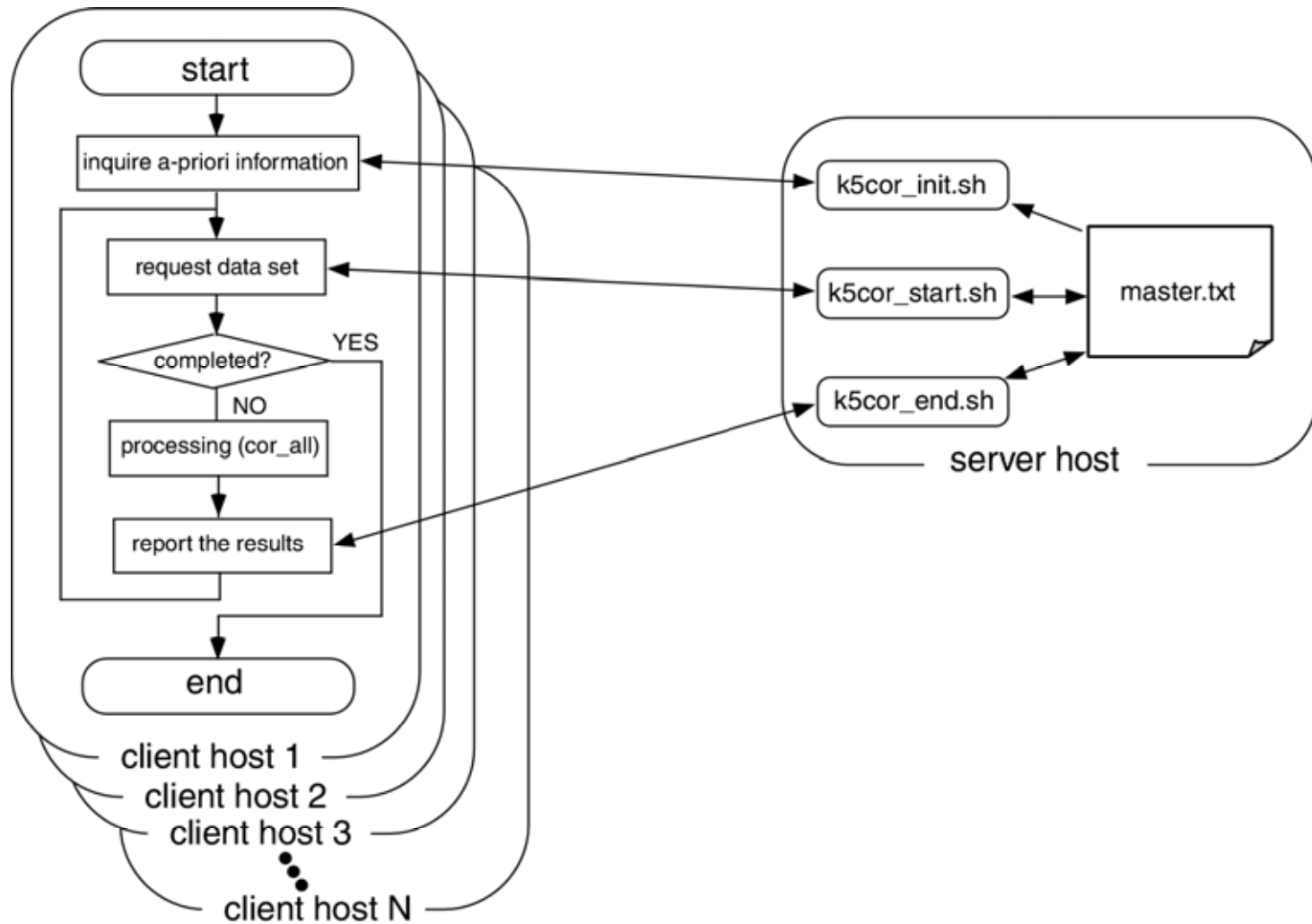

Distributed Software Correlation (3)

VLBI@Home, VLBI@Office

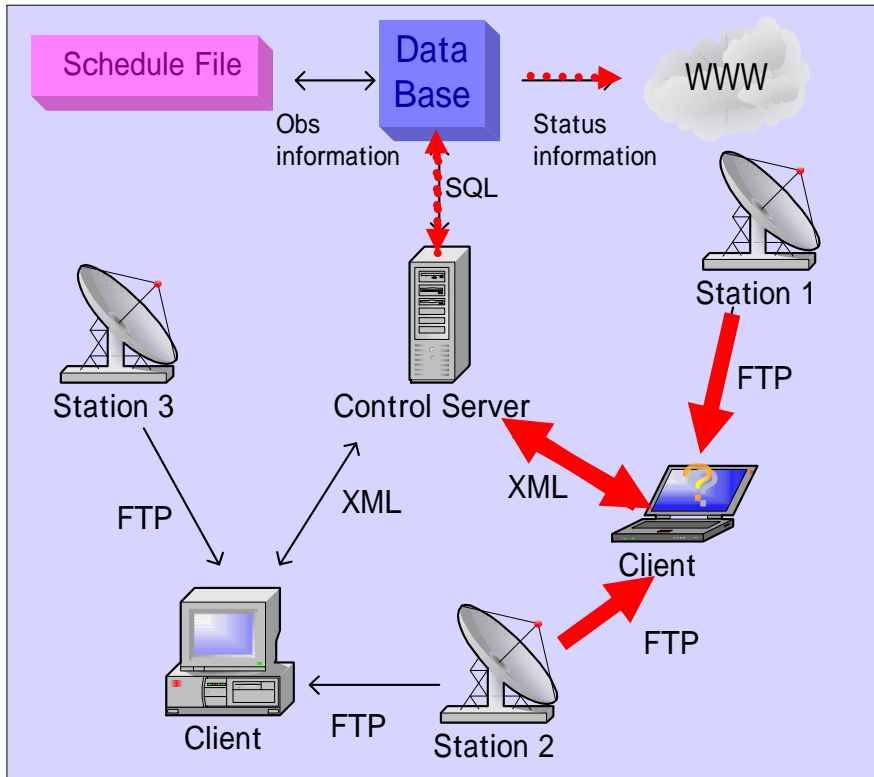

Future Plans (1)

- Faster A/D Sampler

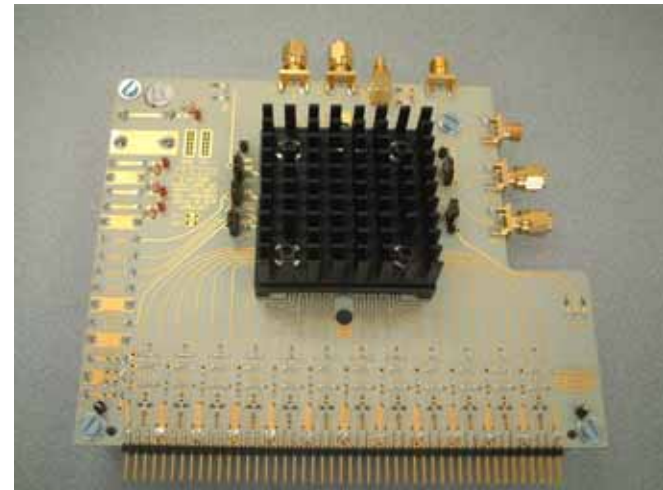

2Gbps/10bit A/D Chip
(Atmel TS83102G0)

Future Plans (2)

- VSI-S, VSI-E
- VSI-H Output
- Control from fs9
- K5/Mark5 e-VLBI Intensive Sessions
(Tsukub32-Wettzell baseline, 1 hour / 1 Week)
- Digital BBC (partially realized)
- Generate PIVEX database from software correlator outputs
- Generate FITS file from software correlator outputs